

# Minimum Excavation Dimensions Required for Pipeline Tap

Note:

- Excavation depth to be 1'0" (min.) below bottom of existing pipe.
- Gravel and/or boards required for footing & support
- Trench is required to be dewatered prior to installation
- Trench to be shored in accordance with OSHA standards
- Customer to provide under valve blocking



888.655.4085 24/7/365 EMERGENCY RESPONSE

4" - 12" Excavation Dimensions

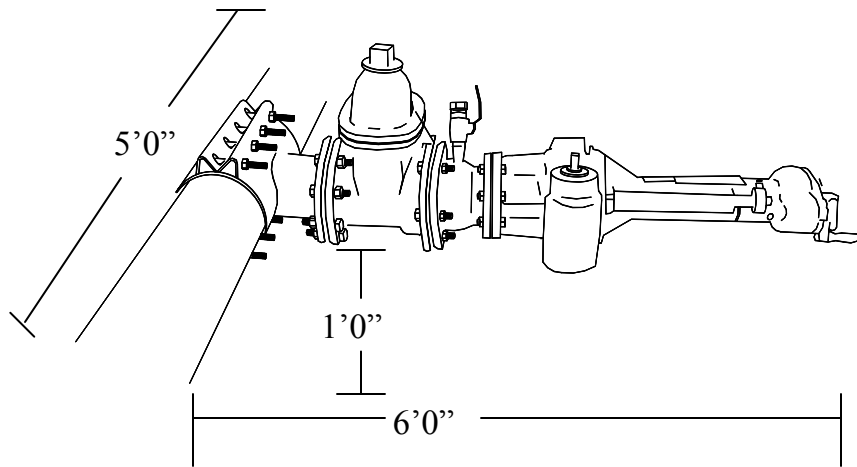

14"-24" Excavation Dimensions

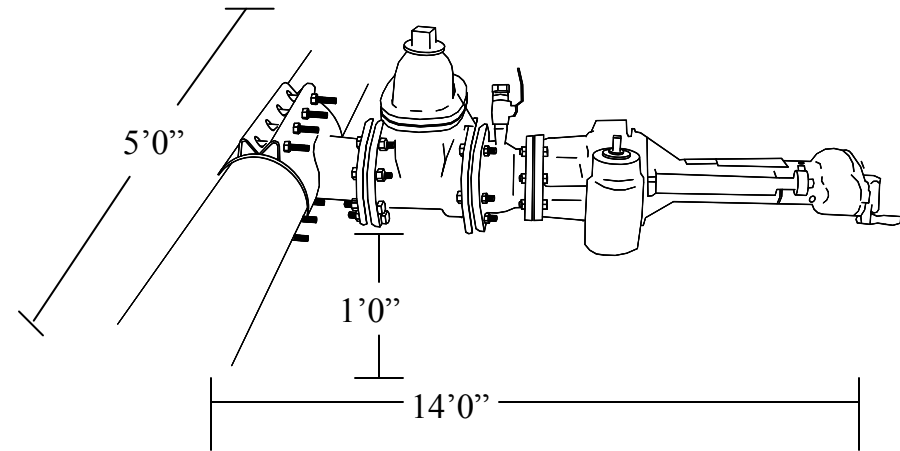

*Larger Taps dimensions given on application*